

**DESCRIPTION:** 5.2 x 20, GLASS CARTRIDGE TIME DELAY FUSE

**PART NO:** PST In

**APPROVALS:**



<b>SPECIFICATIONS</b>	:	IEC 60127-2, SHEET-III
<b>RATED VOLTAGE</b>	:	250 V
<b>BREAKING CAPACITY</b>	:	35 A, AC CURRENT
<b>CAP</b>	:	BRASS, NICKEL PLATED
<b>BODY</b>	:	GLASS BODY

**MARKINGS ON THE FUSE CAP SHOULD BE AS FOLLOWS:-**

TYPE OF FUSE (T), FUSE RATING, RATED VOLTAGE (250V),  
BREAKING CAPACITY (L) & COMPANY'S IDENTIFICATION

**CERTIFICATIONS:**

UL APPROVAL-1A TO 6.3A, 8A AND 10A

ADDITIONAL TEST(FOR<10A) AT 1.5In SHALL NOT FUSE WITHIN 1HOUR

NOMINAL CURRENT (In)	2.1 In MAX.	2.75 In		4 In		10 In	
		MIN.	MAX.	MIN.	MAX.	MIN.	MAX.
32mA TO 100 mA	2 MINUTES	200 mSec	10 Sec	40 mSec	3 Sec	10 mSec	300 mSec
>100mA TO 7.5A&9A	2 MINUTES	600 mSec	10 Sec	150 mSec	3 Sec	20 mSec	300 mSec
8 & 10A	2 MINUTES	500 mSec	10 Sec	150 mSec	3 Sec	20 mSec	300 mSec
>10A	2 MINUTES	600 mSec	10 Sec	150 mSec	3 Sec	20 mSec	300 mSec



**DESCRIPTION:** 5.2 x 20, GLASS CARTRIDGE TIME DELAY FUSE

**PART NO:** PST In

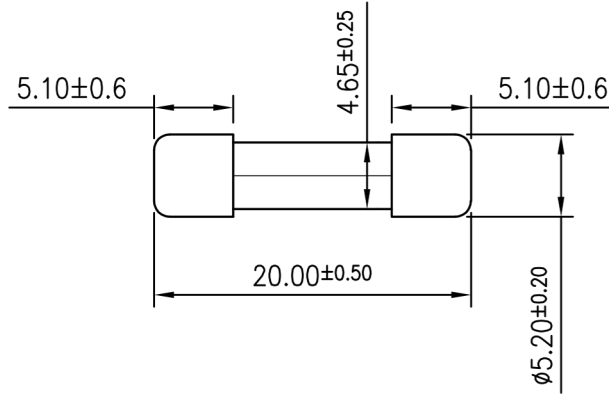

NOTE: FOR MANUAL ASSEMBLY AND OUT SIDE SOLDERING TOTAL LENGTH 20.0+1.0/-0.5mm

SL.NO	PEPL PART NUMBER	NOMINAL CURRENT RANGE (In)	VOLTAGE DROP DC (mV Max.)	SURGE TEST KV
1	PST 0.1A	100 mA	2500	-
2	PST 0.125A	125 mA	2000	-
3	PST 0.15A	150 mA	1900	-
4	PST 0.16A	160 mA	1900	-
5	PST 0.2A	200 mA	1500	-
6	PST 0.25A	250 mA	1300	-
7	PST 0.3A	300 mA	1100	-
8	PST 0.315A	315 mA	1100	-
9	PST 0.35A	350 mA	1100	-
10	PST 0.4A	400 mA	1000	-
11	PST 0.5A	500 mA	900	-
12	PST 0.6A	600 mA	300	-
13	PST 0.63A	630 mA	300	-
14	PST 0.7A	700 mA	250	-
15	PST 0.75A	750 mA	250	-
16	PST 0.8A	800 mA	250	-
17	PST 1A	1 A	150	2
18	PST 1.25A	1.25 A	150	-
19	PST 1.4A	1.4 A	150	-
20	PST 1.5A	1.5 A	150	2

SL.NO	PEPL PART NUMBER	NOMINAL CURRENT RANGE (In)	VOLTAGE DROP DC (mV Max.)	SURGE TEST KV
21	PST 1.6A	1.6 A	150	-
22	PST 2A	2 A	150	3
23	PST 2.5A	2.5 A	120	3
24	PST 3A	3 A	100	5
25	PST 3.15A	3.15 A	100	5
26	PST 3.5A	3.5 A	100	-
27	PST 4A	4 A	100	5
28	PST 5A	5 A	100	6
29	PST 6A	6 A	100	7
30	PST 6.3A	6.3 A	100	7
31	PST 7A	7 A	100	-
32	PST 8A	8 A	100	7
33	PST 9A	9 A	100	-
34	PST 10A	10 A	100	7
35	PST 12A	12 A	100	7
36	PST 15A	15 A	100	6
37	PST 16A	16 A	100	-
38	PST 20A	20 A	100	7
39	PST 30A	30 A	100	-

DESCRIPTION: 5.2 x 20, GLASS CARTRIDGE TIME DELAY FUSE

PART NO: PST In

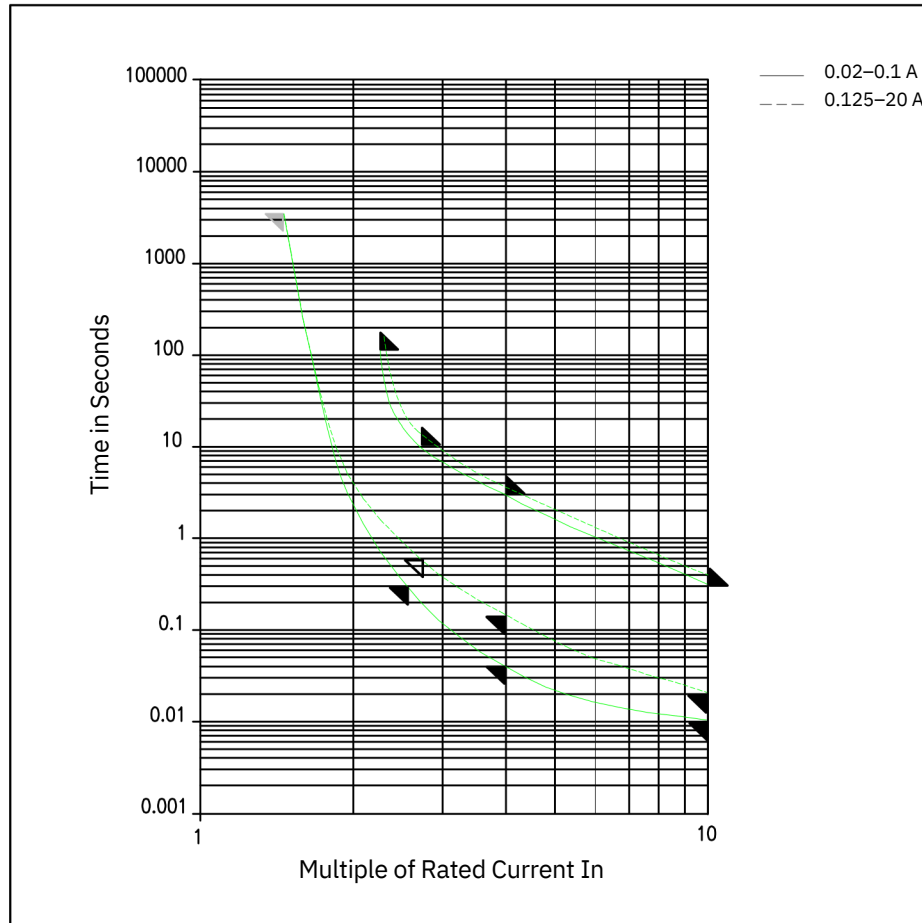

NOTE: IN CASE OF HIGHER SURGE PLEASE CONTACT FACTORY

**ORDERING INFORMATION**

PST... mA ( $I_n \leq 800\text{mA}$ ) OR  
PST... A ( $I_n \geq 1\text{A}$ )

Projection:



Scale: NTS

Sht. Size: A4

Gen. Tol.:  $\pm 0.1\text{mm}$   
 $\pm 0.2^\circ$

ALL DIMENSIONS ARE IN MM.  
IF UNLESS OTHERWISE SPECIFIED.