

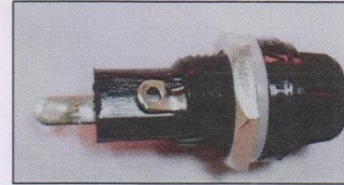

PROTECTRON ELECTROMECH (P) LTD

DESCRIPTION : PANEL MOUNT FUSE HOLDER SCREW TYPE FOR
5.20X20mm FUSE

PART NO: P8028-A1-4



PHYSICAL DATA

INSULATOR BODY	:	BAKELITE
TERMINALS	:	COPPER ALLOY, TIN-PLATED
CAP DESIGN	:	SCREW-IN
FUSE LINK SIZE	:	5.20x20mm
PANEL THICKNESS	:	1.5-3.0mm MAX

ELECTRICAL DATA

MAXIMUM RATED VALUE	:	10A 250V AC
DIELECTRIC WITHSTANDING	:	2K VAC, 3K VDC
INSULATION RESISTANCE	:	1000 MΩ AT 500VDC
CONTACT RESISTANCE	:	20 mΩ MAX



PROTECTRON ELECTROMECH (P) LTD

DESCRIPTION : PANEL MOUNT FUSE HOLDER SCREW TYPE FOR
5.20X20mm FUSE

PART NO: P8028-A1-4

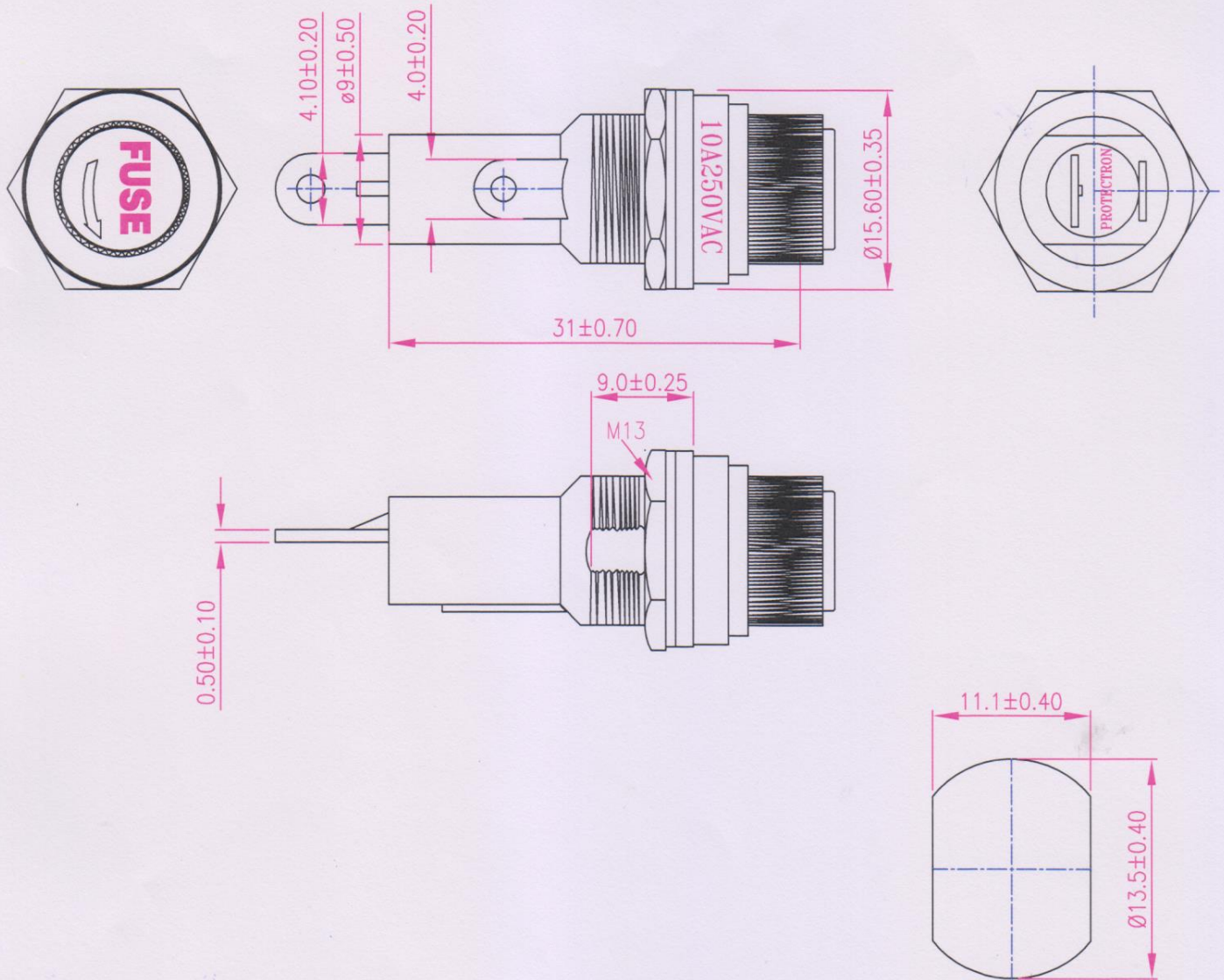

RECOMMENDED PCB LAYOUT

A	ORIGINAL			RAMYA	03.10.2018		<i>Ramya</i>
REV.		DESCRIPTION		DRN. BY	DATE	CK'ED BY	APP'D BY
	Projection:	Scale: NTS	Sht. Size: A4	Gen. Tol.: $\pm 0.35mm$	ALL DIMENSIONS ARE IN MM. IF UNLESS OTHERWISE SPECIFIED.		