

**DESCRIPTION :** ACTUATED CARD-LOCK, WITH FIVE PIECE WEDGES,  
WITH STRAIGHT LEVER,RH

**PART NO. :** P61FA0319-RH

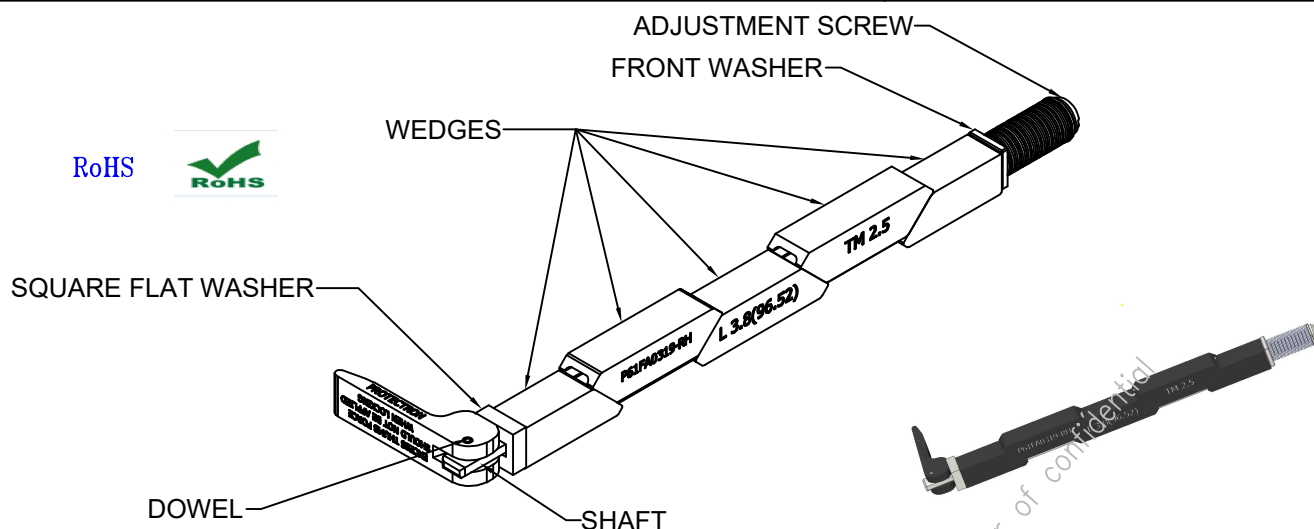

**MATERIAL & FINISH :**

**WEDGES**

- MATERIAL :** Aluminium Alloy 6061-T6/6063 As per, ASTM-B221 or AMS-QQ-A-200/8
- WEDGES :** Also have Dry film lube as per MIL-PRF-46010
- FINISH :** Black Anodize as per MIL-A-8625, Type 2, class 2

**SHAFT**

- MATERIAL :** Stainless Steel 304 Grade as per ASTM-A582

**LEVER**

- MATERIAL :** Aluminium Alloy 6061-T6 as per, ASTM-B221 or AMS-QQ-A-200/8
- FINISH :** Hard Black Anodize as per MIL-A-8625, Type 3, class 2

**ADJUSTMENT SCREW**

- MATERIAL :** Stainless Steel as per ASTM-A582\QQ-S-763
- FINISH :** Passivated per AMS2700

**WASHERS**

- FRONT Washer :** Stainless steel 316 grade as per ASTM-A582
- REAR Washer :** Stainless steel 304/304L grade as per ASTM-A240
- Belleville Washers :** Austenetic stainless steel 316/304 grade as per ASTM-A666
- Finish :** Passivate as per AMS2700

**DESCRIPTION :** ACTUATED CARD-LOCK, WITH FIVE PIECE WEDGES,  
WITH STRAIGHT LEVER,RH

**PART NO. :** P61FA0319-RH

**LEVER OPEN CONDITION**

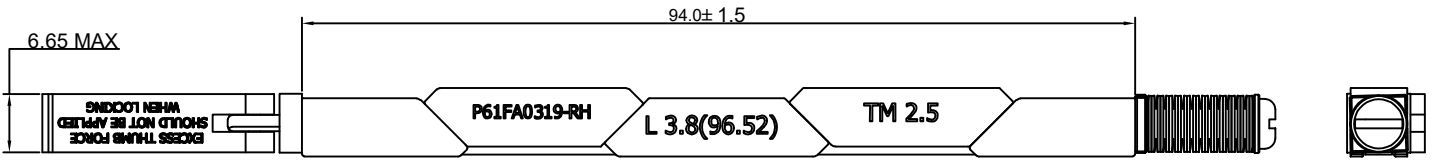

**LEVER CLOSE CONDITION**

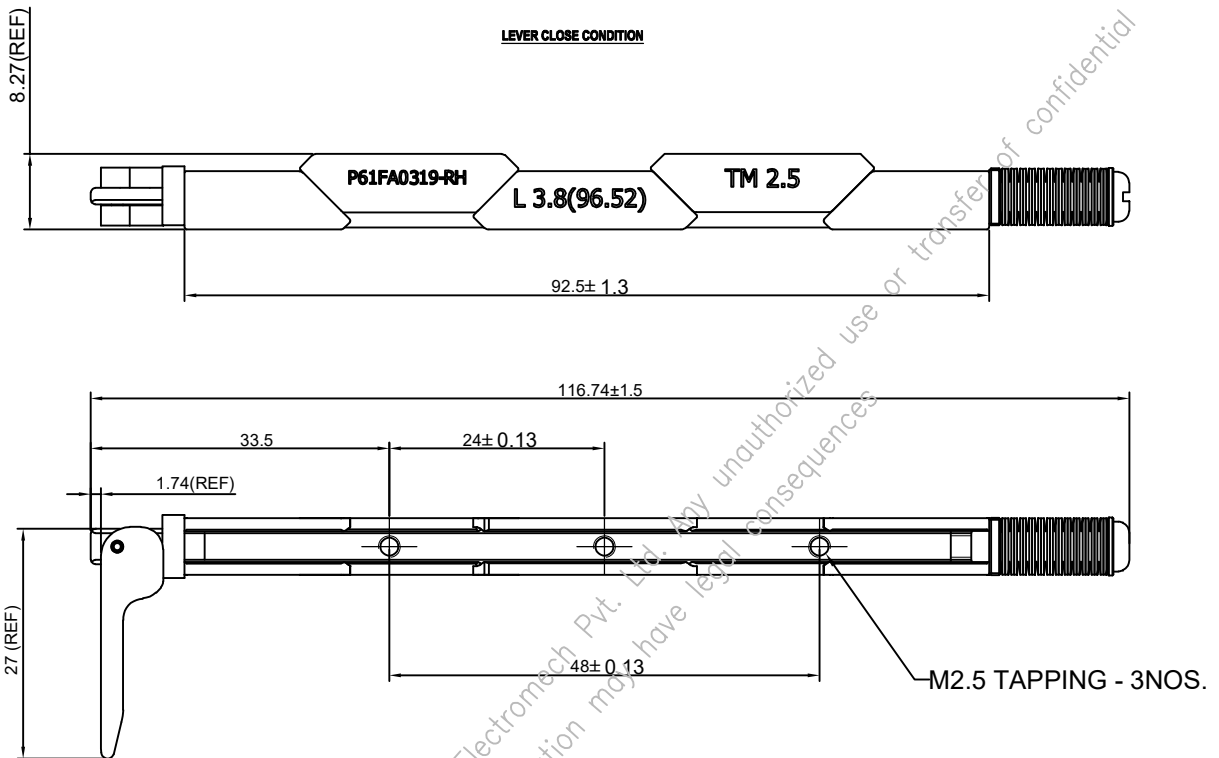

**CLAMPING FORCE ADJUSTMENT PROCEDURE**

- 1) FASTEN LEVER-LOK TO BOARD MODULE ASSEMBLY
- 2) INSERT BOARD MODULE ASSEMBLY INTO SLOT IN COLD PLATE
- 3) ACTUATE LEVER TO LOCKED/CLOSED POSITION
- 4) TIGHTEN SCREW ON END OF SHAFT UNTIL WEDGES INITIALLY CONTACT  
WALL OF COLD PLATE SLOT, OR SLIGHT INSERTION EXTRACTION DRAG IS FELT
- 5) ADDITIONALLY TIGHTEN LOCKNUT TWO FULL TURNS. DO NOT EXCEED TWO TURNS
- 6) LEVER LOK IS NOW READY TO USE.

**Projection:**



**Scale:** NTS

**Sht. Size:** A4

**Gen. Tol.:** ±0.5mm **ALL DIMENSIONS ARE IN MM.  
IF UNLESS OTHERWISE SPECIFIED.**