

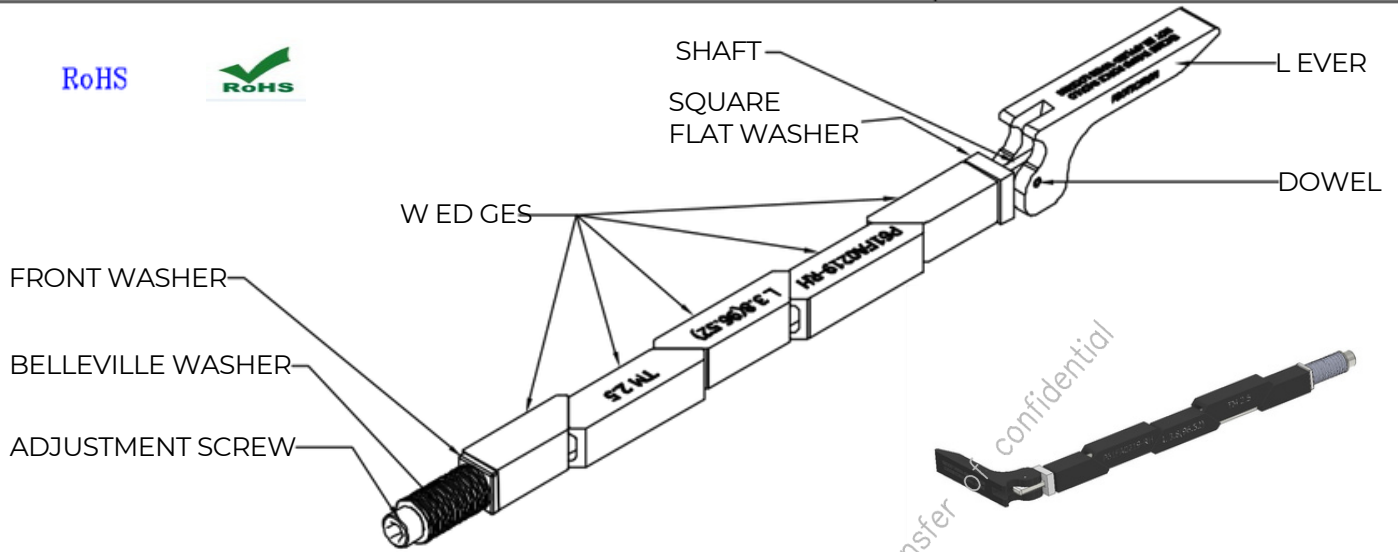

DESCRIPTION : ACTUATED CARD-LOCK, WITH FIVE PIECE WEDGES, WITH EJECTOR TYPE LEVER, RH

PART NO. : P61FA0219-RH

RoHS



MATERIAL & FINISH :

WEDGES

- MATERIAL :** Aluminium Alloy 6061-T6/6063 As per, ASTM-B221 or AMS-QQ-A-200/8
- WEDGES :** Also have Dry film lube as per MIL-PRF-46010
- FINISH :** Black Anodize as per MIL-A-8625, Type 2, class 2

SHAFT

- MATERIAL :** Stainless Steel 304 Grade as per ASTM-A582

LEVER

- MATERIAL :** Aluminium Alloy 6061-T6 as per, ASTM-B221 or AMS-QQ-A-200/8
- FINISH :** Hard Black Anodize as per MIL-A-8625, Type 3, class 2

ADJUSTMENT SCREW

- MATERIAL :** Stainless Steel as per ASTM-A582\QQ-S-763
- FINISH :** Passivated as per AMS2700

WASHERS

- FRONT Washer :** Stainless steel 316 grade as per ASTM-A582
- REAR Washer :** Stainless steel 304/304L grade as per ASTM-A240
- Belleville Washers :** Austenetic stainless steel 316/304 grade as per ASTM-A666
- Finish :** Passivate as per AMS2700



DESCRIPTION : ACTUATED CARD-LOCK, WITH FIVE PIECE WEDGES, WITH EJECTOR TYPE LEVER, RH

PART NO. : P61FA0219-RH

LEVER OPEN CONDITION

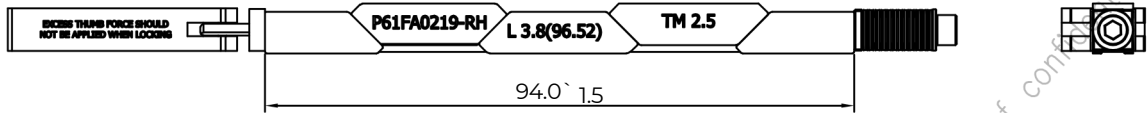

LEVER CLOSE CONDITION

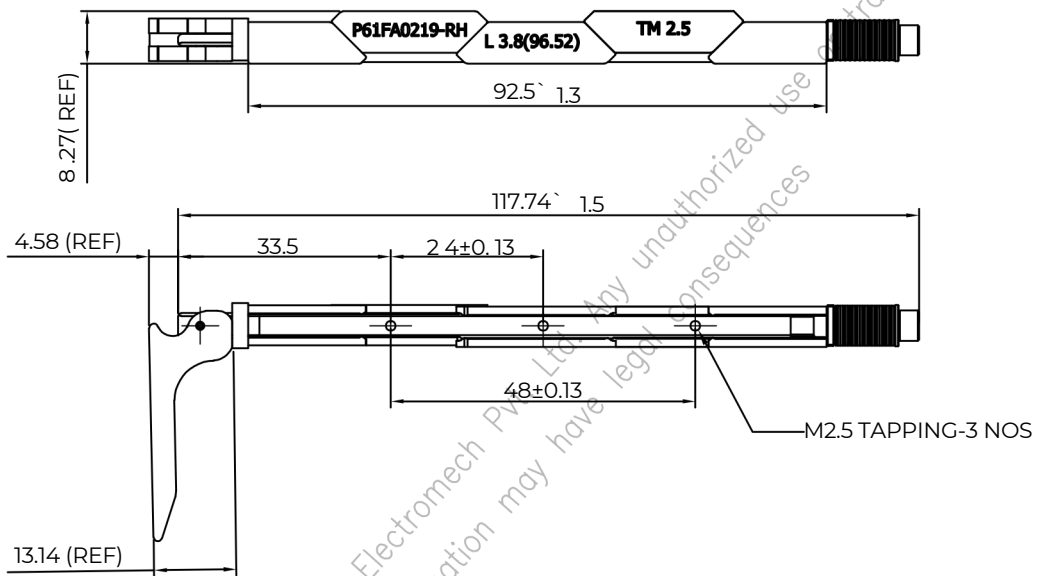

CLAMPING FORCE ADJUSTMENT PROCEDURE

- 1) FASTEN LEVER-LOK TO BOARD MODULE ASSEMBLY.
- 2) INSERT BOARD MODULE ASSEMBLY INTO SLOT IN COLD PLATE.
- 3) ACTUATE LEVER TO LOCKED/CLOSED POSITION.
- 4) TIGHTEN SCREW ON END OF SHAFT UNTIL WEDGES INITIALLY CONTACT WALL OF COLD PLATE SLOT, OR SLIGHT INSERTION EXTRACTION DRAG IS FELT.
- 5) ADDITIONALLY TIGHTEN LOCKNUT TWO FULL TURNS. DO NOT EXCEED TWO TURNS.
- 6) LEVER LOK IS NOW READY TO USE.

Projection:



Scale:NTS

Sht. Size:A4

Gen. Tol.: ±0.5mm

**ALL DIMENSIONS ARE IN MM.
IF UNLESS OTHERWISE SPECIFIED.**