

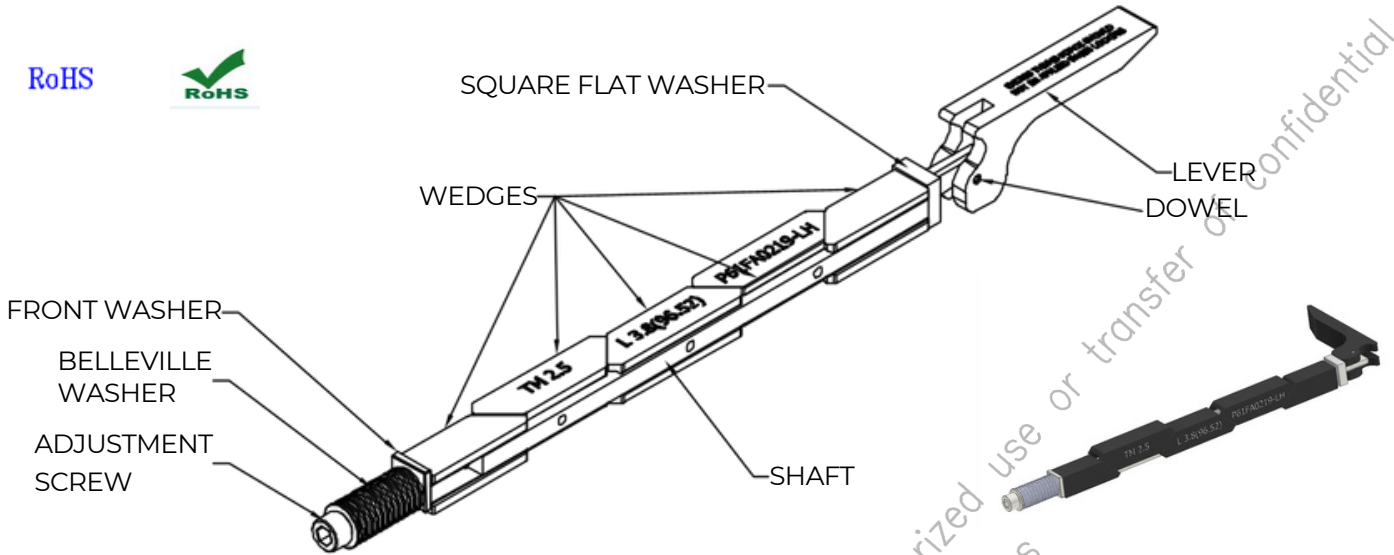

**DESCRIPTION :** ACTUATED CARD-LOCK, WITH FIVE PIECE WEDGES, WITH EJECTOR TYPE LEVER, LH

**PART NO. :** P61FA0219-LH

RoHS



**MATERIAL & FINISH :**

**WEDGES**

- MATERIAL** : Aluminium Alloy 6061-T6/6063 As per, ASTM-B221 or AMS-QQ-A-200/8
- WEDGES** : Also have Dry film lube as per MIL-PRF-46010
- FINISH** : Black Anodize as per MIL-A-8625, Type 2, class 2

**SHAFT**

- MATERIAL** : Stainless Steel 304 Grade as per ASTM-A582

**LEVER**

- MATERIAL** : Aluminium Alloy 6061-T6 as per, ASTM-B221 or AMS-QQ-A-200/8
- FINISH** : Hard Black Anodize as per MIL-A-8625, Type 3, class 2

**ADJUSTMENT SCREW**

- MATERIAL** : Stainless Steel as per ASTM-A582\QQ-S-763
- FINISH** : Passivated as per AMS2700

**WASHERS**

- FRONT Washer** : Stainless steel 316 grade as per ASTM-A582
- REAR Washer** : Stainless steel 304/304L grade as per ASTM-A240
- Belleville Washers** : Austenetic stainless steel 316/304 grade as per ASTM-A666
- Finish** : Passivate as per AMS2700

**DESCRIPTION :** ACTUATED CARD-LOCK, WITH FIVE PIECE WEDGES, WITH EJECTOR TYPE LEVER, LH

**PART NO. :** P61FA0219-LH

LEVER OPEN CONDITION

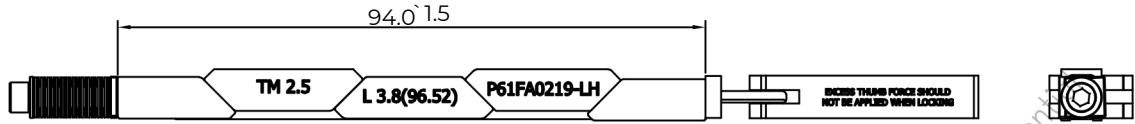

LEVER CLOSE CONDITION

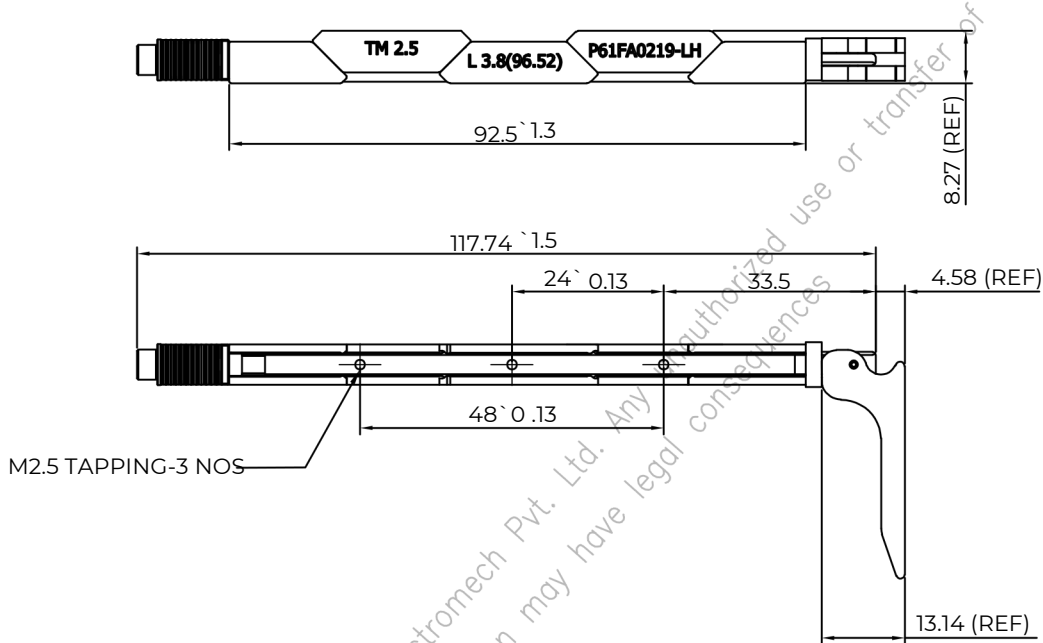

**CLAMPING FORCE ADJUSTMENT PROCEDURE**

- 1) FASTEN LEVER-LOK TO BOARD MODULE ASSEMBLY.
- 2) INSERT BOARD MODULE ASSEMBLY INTO SLOT IN COLD PLATE.
- 3) ACTUATE LEVER TO LOCKED/CLOSED POSITION.
- 4) TIGHTEN SCREW ON END OF SHAFT UNTIL WEDGES INITIALLY CONTACT  
WALL OF COLD PLATE SLOT, OR SLIGHT INSERTION EXTRACTION DRAG IS FELT.
- 5) ADDITIONALLY TIGHTEN LOCKNUT TWO FULLY TURNS. DO NOT EXCEED TWO TURNS.
- 6) LEVER LOK IS NOW READY TO USE.

**Projection:**



**Scale:** NTS

**Sht. Size:** A4

**Gen. Tol.:** ±0.5mm

**ALL DIMENSIONS ARE IN MM.  
IF UNLESS OTHERWISE SPECIFIED.**