



# PROTECTRON ELECTROMECH (P) LTD

**DESCRIPTION** : PCB CONNECTOR 2.54mm ,  
SINGLE ROW , SOLDER TAIL ,  
ACCEPTS ROUND PINS Ø0.70-00.8mm

**PART NO:** P9305-XX-41-1  
1st XX=NO OF CONTACTS(1-40)

RoHS

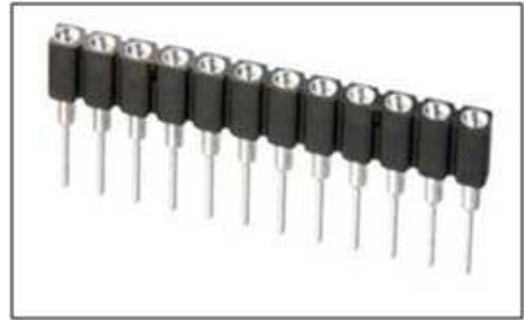

## PHYSICAL

### INSULATION

|                |   |  |
|----------------|---|--|
| MATERIAL       | : | GLASS FILLED POLYESTER, SELF EXTINGUISHING |
| FLAMMABILITY   | : | UL94V-0/PPS                                |
| COLOR          | : | BLACK                                      |
| SLEEVE         | : | BRASS, TIN PLATED                          |
| CLIP           | : | BERYLLIUM COPPER, GOLD PLATED              |
| PACKAGING TYPE | : | TUBE/TRAY                                  |

## ELECTRICAL

|                       |   |                 |
|-----------------------|---|-----------------|
| CURRENT RATING        | : | 3A              |
| INSULATION RESISTANCE | : | 10000M OHMS MIN |
| VOLTAGE PROOF         | : | 1000V rms AC    |
| CONTACT RESISTANCE    | : | 10m OHMS MAX.   |
| VOLTAGE RATING        | : | 100V AC         |

## ENVIRONMENTAL DATA

|                      |   |                     |
|----------------------|---|---------------------|
| TEMPERATURE RANGE    | : | -65°C TO +125°C     |
| PROCESS RATING       | : | ±260°C , 10 Seconds |
| ENVIRONMENT CATEGORY | : | 65/125/21           |



# PROTECTRON ELECTROMECH (P) LTD

DESCRIPTION : PCB CONNECTOR 2.54mm ,  
SINGLE ROW , SOLDER TAIL ,  
ACCEPTS ROUND PINS Ø0.70-Ø0.8mm

PART NO: P9305-XX-41-1  
1st XX=NO OF CONTACTS(1-40)

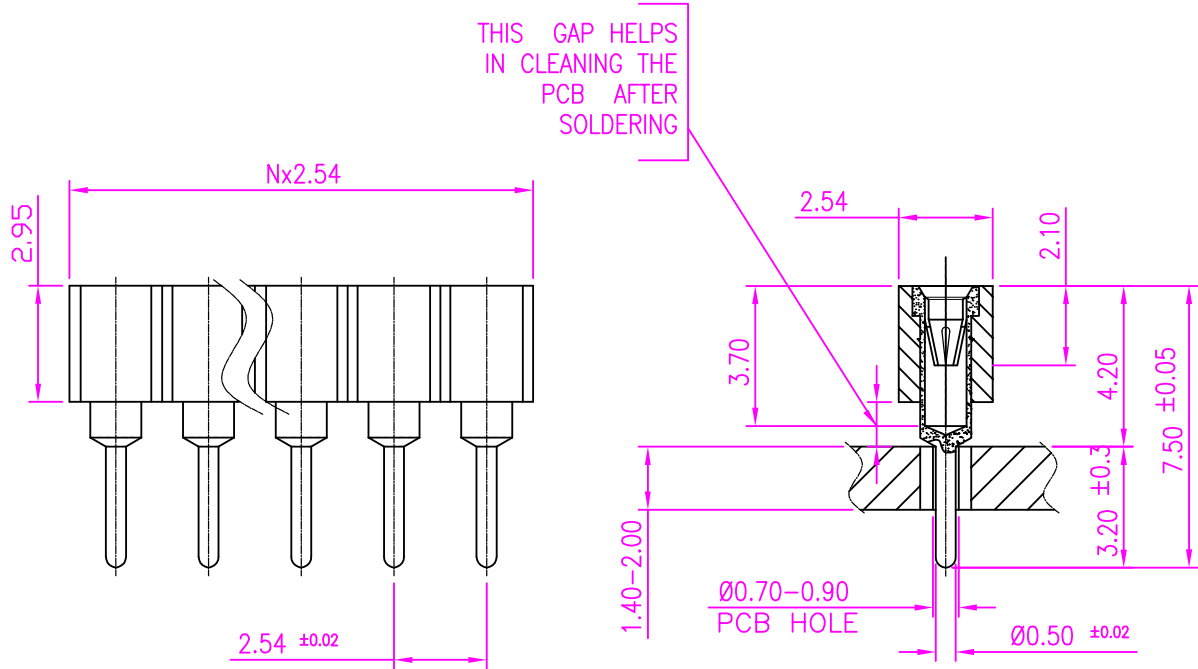

**MATES WITH**

P9101, P9102  
P9107, P9109

**ORDERING INFORMATION**

P9305-XX-41-1

NO OF CONTACTS  
(1-40)

MOQ- ----

SPQ- ----

|      |                           |         |            |          |          |
|------|---------------------------|---------|------------|----------|----------|
| A1   | TECHNICAL DATA IS REVISED | SAMSON  | 10.08.2001 |          |          |
| A    | ORIGINAL                  | GK      | 25.04.2000 |          |          |
| REV. | DESCRIPTION               | DRN. BY | DATE       | CK'ED BY | APP'D BY |

Projection:

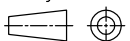

Scale: NTS

Sht. Size: A4

Gen. Tol.:  $\pm 0.35\text{mm}$

ALL DIMENSIONS ARE IN MM.  
IF UNLESS OTHERWISE SPECIFIED.